

GENERAL TIRE



ST250



GENERAL TIRE
MEDIUM TRUCK

ST250

LONG HAUL TRAILER

Visual Alignment Indicators (VAI)[®] alerts users to tire tracking problems.

Stone ejection system reduces stone retention and casing penetrations.

13/32" tread depth minimizes tread squirm and irregular wear.

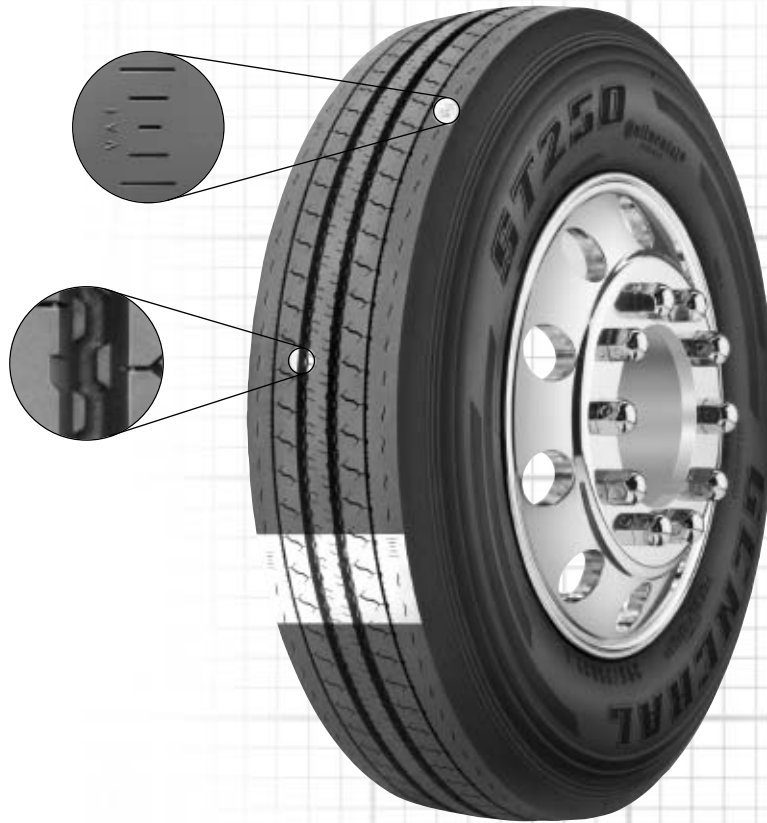

Applications:
Long haul trailer.

TIRE SPECIFICATIONS Highway - 75 mph at loads indicated unless otherwise stated.

TIRE SIZE	LOAD RANGE	TREAD DEPTH	PRODUCT CODE	SAP ARTICLE NUMBER	RIM WIDTH IN	OVERALL INFLATED DIAMETER IN (mm)	OVERALL INFLATED WIDTH IN (mm)	LOADED SECTION WIDTH IN (mm)	STATIC LOADED RADIUS IN (mm)	MINIMUM DUAL SPACING IN (mm)	REVS PER MILE (KM)	TIRE WEIGHT LB (KG)	MAX LOAD@INFLATION			
													SINGLE		DUAL	
												lbs (KG)	psi (KPa)	lbs (KG)	psi (KPa)	
TUBELESS TIRES ON 15 DEGREE DROP CENTER RIMS																
11R22.5	G	13/32	0237211	05681790000	8.25	41.1 (1045)	11.1 (282)	12.2 (310)	19.3 (489)	12.5 (318)	503 (312)	108 (49)	6175 (2800)	105 (720)	5840 (2650)	105 (720)
11R24.5	G	13/32	0237267	05681810000	8.25	43.1 (1096)	11.2 (284)	12.2 (310)	20.4 (518)	12.5 (318)	475 (295)	115 (52)	6610 (3000)	105 (720)	6005 (2725)	105 (720)
295/75R22.5	G	13/32	0237285	05684630000	8.25	39.8 (1011)	11.0 (279)	12.0 (305)	18.5 (471)	12.5 (318)	518 (322)	102 (46)	6175 (2800)	110 (760)	5675 (2575)	110 (760)
285/75R24.5	G	13/32	0237288	05684640000	8.25	41.0 (1042)	10.9 (278)	12.0 (305)	19.1 (485)	12.5 (318)	504 (313)	106 (48)	6175 (2800)	110 (760)	5675 (2575)	110 (760)

Note: Minimum Dual Spacing calculated without chains.
These specifications subject to change without notice.